

# Hygienic 80

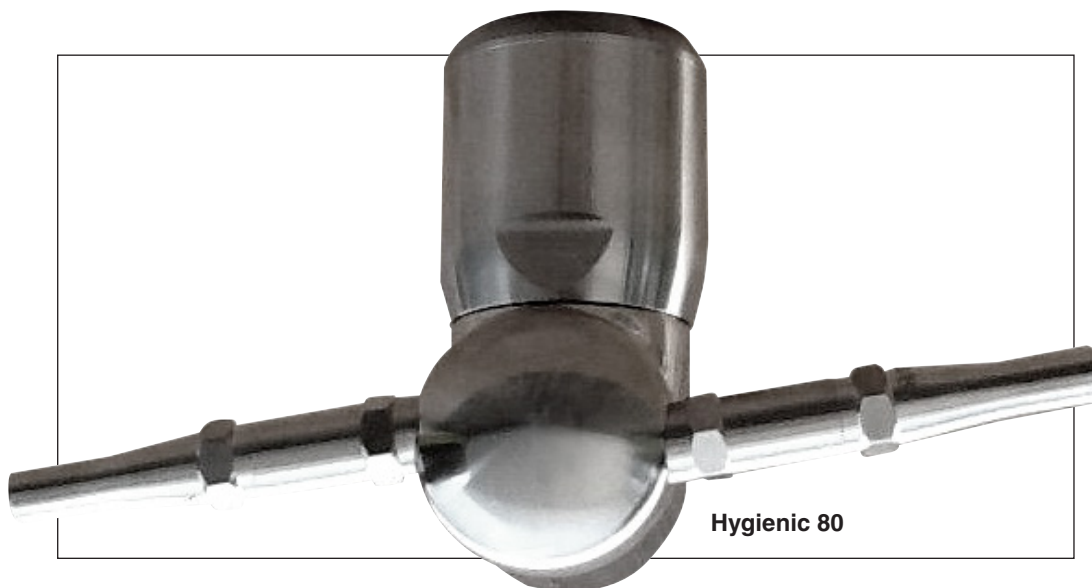

Hygienic 80

The new Hygienic 80 design incorporates the proven performance and self-cleaning, self-draining capabilities of the current dual- and triple-nozzle Tankman models, but it also offers a more hygienic appearance — with no exposed gears, a larger selection of nozzle orifices, less component parts and improved performance.

The Hygienic 80 effectively and thoroughly cleans the tanks and process vessels, with a minimum of cost and maintenance, for a variety of applications in the brewing, chemical processing, food processing and pharmaceutical industries. Both dual- and triple-nozzle models are

hydraulically driven by the cleaning solution and will provide a thorough 360-degree cleaning pattern every 45 revolutions. The hydraulic drive gives it longer life and more reliability, without any internal drive gears to worry about. Ease of field maintenance!

## Specifications

<b>Operating Pressure</b>	50–200 PSI (3.4–13.8 bar)
<b>Flow Capacity</b>	25–135 GPM (95–511 l/m)
<b>Maximum Operating Temperature</b>	250 °F (120 °C)
<b>Effective Cleaning Radius</b>	25 ft (7.6 m)
<b>Effective Wetting Radius</b>	40 ft (12 m)
<b>Pipe Connection</b>	1½" NPT, BSPT (optional sanitary)
<b>Nozzle Orifices</b>	¼" (6.35 mm), ⅜" (7.8 mm), ½" (9.5 mm), ⅝" (11 mm)
<b>Approximate Weight</b>	12lbs (5.44kg)
<b>Materials</b>	316 stainless steel and FDA approved 21 CFR 177 polymers
<b>Minimum Opening</b>	5.52 (140 mm) — Dual; 11.96 (304 mm) — Triple
<b>Cycle Time</b>	3–8 minutes

# Technical Information

## Hygienic 80 — Dual-Nozzle

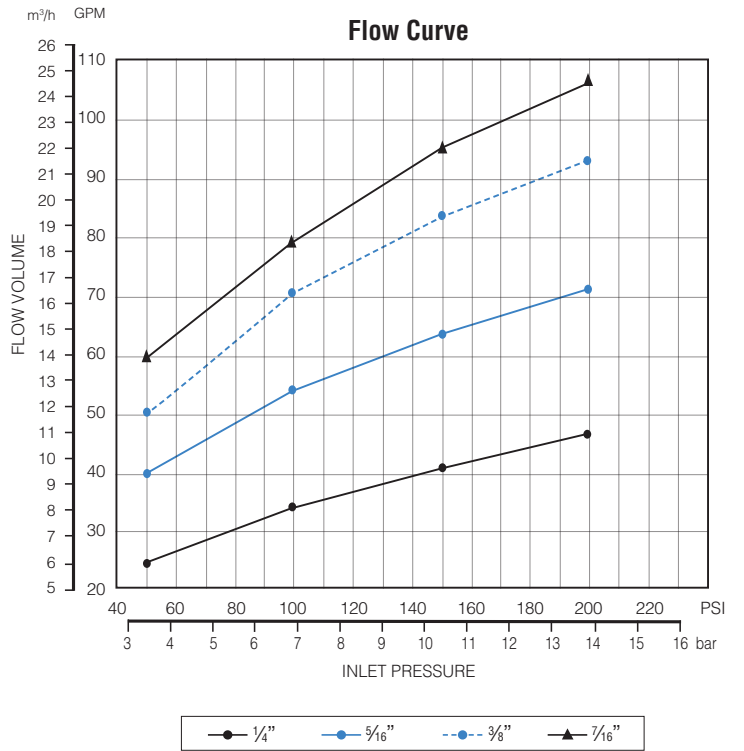
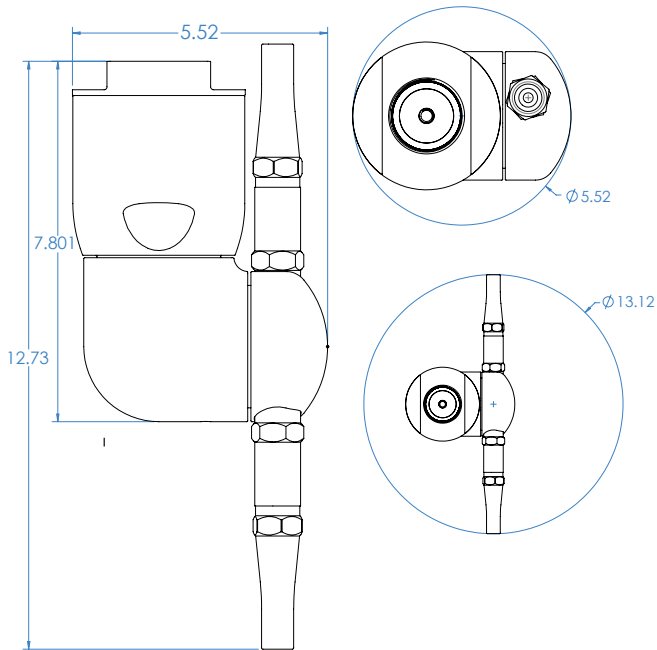

## Hygienic 80 — Triple-Nozzle

