

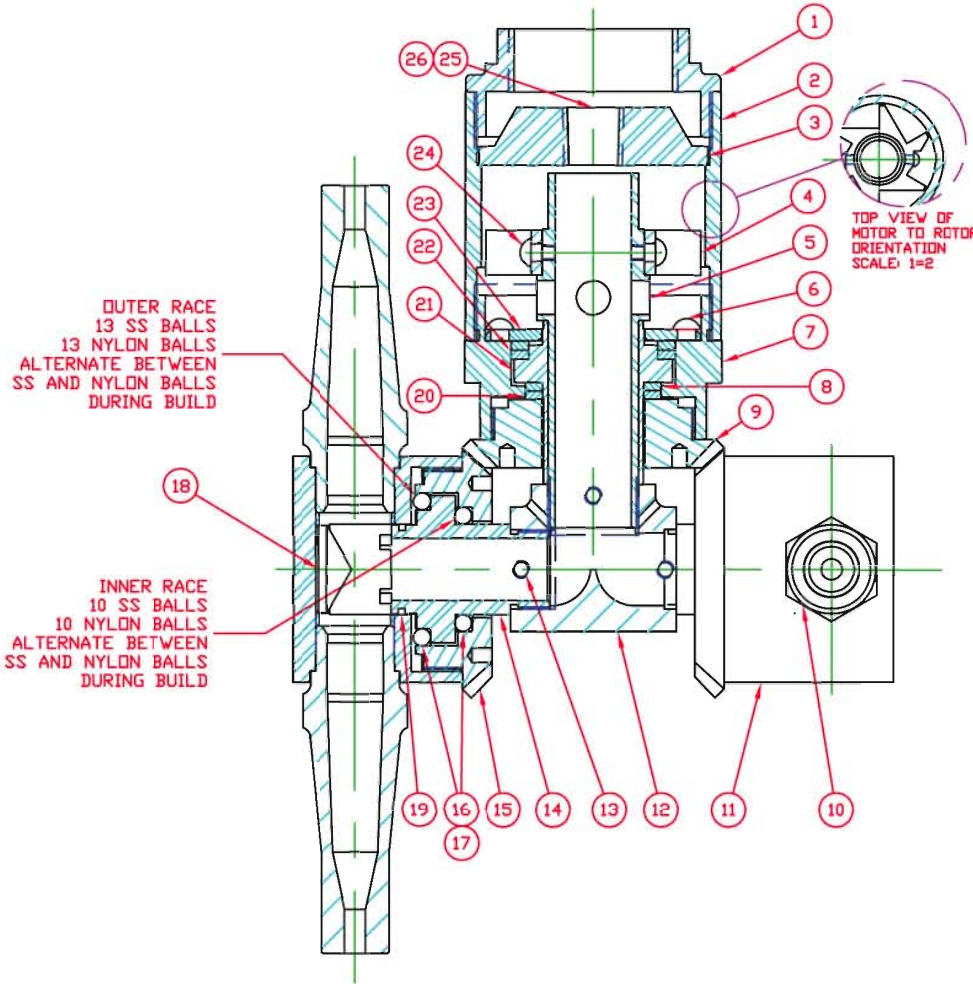

PART No.	ITEM #1	ITEM #3	ITEM #10	ITEM #25
J6-500-DA	75-1603	J6-101	J6-115-DA	J6-119-B
J6-500-FA	75-1603	J6-201	J6-115-FA	J6-119-A
J6-500-GA	75-1603	J6-201	J6-115-GA	J6-119-D
J6-500-DA-BSP	75-1603-BSP	J6-101	J6-115-DA	J6-119-B
J6-500-FA-BSP	75-1603-BSP	J6-201	J6-115-FA	J6-119-A
J6-500-GA-BSP	75-1603-BSP	J6-201	J6-115-GA	J6-119-D

NOTES:

- 1) ASSEMBLE UNIT WITH NOZZLES PERPENDICULAR TO EACH OTHER.
- 2) WEIGHT PER UNIT = 12 LBS.
SHIPPING WEIGHT = 14 LBS.
- 3) USE THE FOLLOWING TORQUES FOR ASSEMBLY:
ITEMS #9 AND #15 TO 100 FT/LBS.
ITEM #13 TO 20 IN/LBS.
ITEM #10 AND #1 TO 80 FT/LBS.
- 4) NOZZLE BODY INNER RACE HAS 10 BALLS.
NOZZLE BODY OUTER RACE HAS 13 BALLS.
- 5) SPARE PARTS KIT NUMBER J6-500-SPK
PARTS FOR THE KIT ARE IDENTIFIED WITH AN 



	26	1	75-1410	PLUG,BY-PASS,3/8" NPT	
	25	1	SEE CHART	PLUG,BY-PASS,3/8" NPT	
	24	2	2-61-1	SCREW,RH,#8-32 X 3/8"	18-8-SS
	23	1	J6-106	PLATE,BEARING RETAINER	SS
	22	2	J6-240	WASHER,VERTICAL SHAFT	
	21	1	J6-107	BUSHING,VERTICAL SHAFT BEARING	SS
	20	1	J6-341	WASHER,THRUST,1.125x1.465	TEFLON
	19	2	2-31050-020	O-RING	TEFLON
	18	2	J6-314-SSA	SPLITTER,FLOW (PRESS FIT INTO J6-313)	
	17	46	J6-133	BALL,NYLON,Ø.156	NYLON
	16	46	74-1172	BALL,STAINLESS,Ø.187	SS
	15	2	J6-309-EP	GEAR,44 TEETH BEVEL	
	14	2	J6-112	SHAFT,NOZZLE HEAD	SS
	13	3	74-324	SCREW,SH,#10-32 X 1/4"	
	12	1	J6-110	TEE,VERTICAL & HORIZONTAL	316SS
	11	2	J6-313	BODY,NOZZLE (2 NOZZLES)	SS
	10	4	SEE CHART	NOZZLE	
	9	1	J6-308-EP	GEAR,45 TEETH BEVEL	
	8	1	J6-241	WASHER,VERTICAL SHAFT BRG	POLY
	7	1	J6-305	CAP,LOWER,BODY	SS
	6	3	2-60-1	SCREW,RH,#8-32 X 5/16	18-8-SS
	5	1	J6-102	SHAFT,VERTICAL	SS
	4	1	J6-104	ROTOR,6-TOOTH	316SS
	3	1	SEE CHART	MOTOR	316SS
	2	1	75-1601	BODY,OUTER	SS
	1	1	SEE CHART	CAP,INLET	SS
ITEM NO.	QTY REQD	PART OR IDENTIFYING NO.	NOMENCLATURE OR DESCRIPTION		MATERIAL/SPECIFICATION
			PARTS LIST		

THIS PRINT IS AND CONTAINS PROPRIETARY INFORMATION OWNED EXCLUSIVELY BY SELLERS CLEANING SYSTEMS AND CLOUD TANK COMPANY. THIS RESTRICTION INCLUDES, BUT IS NOT LIMITED TO, THE CONDITION THAT THIS PRINT WILL ONLY BE USED AS A RECORD OR TO IDENTIFY OR INSPECT PARTS OR FOR OTHER INFORMATION PURPOSES, AND WILL NOT BE USED TO MANUFACTURE OR PROCURE THE MANUFACTURE OF THE PARTS SHOWN IN THIS PRINT BY ANY OTHER SOURCE THAN SELLERS CLEANING SYSTEMS AND CLOUD TANK COMPANY.

THIS DRAWING IS APPROVED FOR UNCONTROLLED DISTRIBUTION

AS A RESULT OF SELLERS CLEANING SYSTEMS CONSTANT PRODUCT IMPROVEMENT PROGRAM, PRODUCT CHANGES MAY OCCUR. AS SUCH, SELLERS CLEANING SYSTEMS RESERVES THE RIGHT TO CHANGE PRODUCT WITHOUT PRIOR WRITTEN NOTIFICATION

WWW.SELLERSCLEAN.COM SHEET 3 OF 3

TITLE: JUMBO 6

CAGE NO: 96046

DWG NO: CDJ6-500-XX REV: E



4

3

2

1

PART No.	ITEM #1	ITEM #3	ITEM #10
J6-500-BD-DA	75-1603	J6-101-D	J6-115-DA
J6-500-BD-FA	75-1603	J6-101-R	J6-115-FA
J6-500-BD-GA	75-1603	J6-101-J	J6-115-GA
J6-500-BD-DA-BSP	75-1603-BSP	J6-101-D	J6-115-DA
J6-500-BD-FA-BSP	75-1603-BSP	J6-101-R	J6-115-FA
J6-500-BD-GA-BSP	75-1603-BSP	J6-101-J	J6-115-GA

UPPER RACE
14 SS BALLS
14 NYLON BALLS
ALTERNATE BETWEEN
SS AND NYLON BALLS
DURING BUILD

LOWER RACE
11 SS BALLS
11 NYLON BALLS
ALTERNATE BETWEEN
SS AND NYLON BALLS
DURING BUILD

OUTER RACE
13 SS BALLS
13 NYLON BALLS
ALTERNATE BETWEEN
SS AND NYLON BALLS
DURING BUILD

INNER RACE
10 SS BALLS
10 NYLON BALLS
ALTERNATE BETWEEN
SS AND NYLON BALLS
DURING BUILD

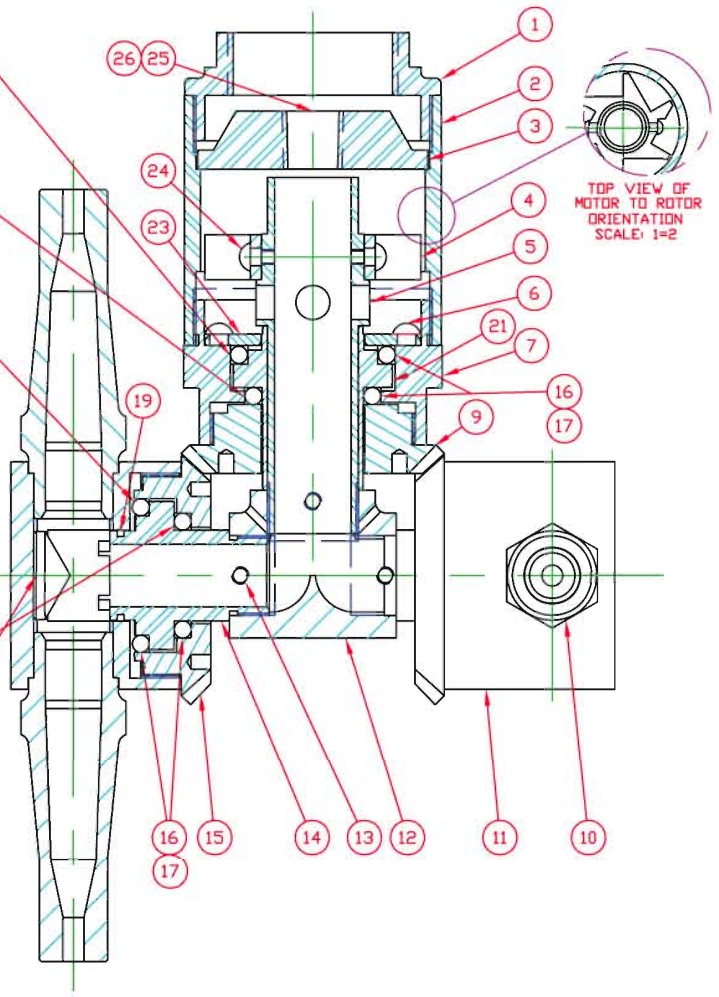

- NOTES:**
- ASSEMBLE UNIT WITH NOZZLES PERPENDICULAR TO EACH OTHER.
 - APPLY A SMALL AMOUNT OF NEVER-SEEZ LUBRICANT (625-03561) TO ALL THREADS AT ASSEMBLY TO PREVENT GALLING.
 - WEIGHT PER UNIT = 12 LBS.
SHIPPING WEIGHT = 14 LBS.
 - USE THE FOLLOWING TORQUES FOR ASSEMBLY:
ITEMS #8 AND #14 TO 100 FT/LBS.
ITEM #12 TO 20 IN/LBS.
ITEM #9 TO 80 FT/LBS.
ITEM #1 TO 80 FT/LBS.
 - NOZZLE BODY INNER RACE HAS 10 BALL'S EACH.
NOZZLE BODY OUTER RACE HAS 13 BALL'S EACH.
 - VERTICLE SHAFT UPPER RACE HAS 14 BALL'S.
VERTICLE SHAFT LOWER RACE HAS 11 BALL'S.
 - SPARE PARTS KIT NUMBER J6-500-BD-SPK.
PARTS FOR THE KIT ARE IDENTIFIED WITH AN

	26	1	75-1410	PLUG,SOCKET,3/8" NPT	
	25	1	J6-119-GA	PLUG,SOCKET,3/8" NPT	
	24	2	2-61-1	SCREW,RH,#8-32 X 3/8"	18-8-SS
	23	1	J6-106	PLATE,BEARING RETAINER	SS
	21	1	J6-107	BUSHING,VERTICAL SHAFT BEARING	SS
	19	2	2-310050-020	O-RING	TEFLON
	18	2	J6-314-SSA	SPLITTER,FLOW (PRESS FIT INTO J6-313)	
	17	71	J6-133	BALL,NYLON,±156	NYLON
	16	71	74-1172	BALL,STAINLESS,±187	SS
	15	2	J6-309-EP	GEAR,44 TEETH BEVEL	
	14	2	J6-112	SHAFT,NOZZLE HEAD	SS
	13	3	74-324	SCREW,SH,#10-32 X 1/4"	
	12	1	J6-110	TEE,VERTICAL & HORIZONTAL	316SS
	11	2	J6-313	BODY,NOZZLE (2 NOZZLES)	SS
	10	4	SEE CHART	NOZZLE	
	9	1	J6-308-EP	GEAR,45 TEETH BEVEL	
	7	1	J6-305	CAP,LOWER,BODY	SS
	6	3	2-60-1	SCREW,RH,#8-32 X 5/16	18-8-SS
	5	1	J6-102	SHAFT,VERTICAL	SS
	4	1	J6-104	ROTOR,6-TOOTH	316SS
	3	1	SEE CHART	MOTOR	316SS
	2	1	75-1601	BODY,OUTER	SS
	1	1	SEE CHART	CAP,INLET	SS
ITEM NO.	QTY REQD	PART OR IDENTIFYING NO.	NOMENCLATURE OR DESCRIPTION	MATERIAL/SPECIFICATION	

THIS PRINT IS AND CONTAINS PROPRIETARY INFORMATION OWNED EXCLUSIVELY BY SELLERS CLEANING SYSTEMS AND CLOUD TANK COMPANY. THIS RESTRICTION INCLUDES, BUT IS NOT LIMITED TO, THE CONDITION THAT THIS PRINT WILL ONLY BE USED AS A RECORD OR TO IDENTIFY OR INSPECT PARTS OR FOR OTHER INFORMATION PURPOSES, AND WILL NOT BE USED TO MANUFACTURE OR PROCURE THE MANUFACTURE OF THE PARTS SHOWN IN THIS PRINT BY ANY OTHER SOURCE THAN SELLERS CLEANING SYSTEMS AND CLOUD TANK COMPANY.

THIS DRAWING IS APPROVED FOR UNCONTROLLED DISTRIBUTION

AS A RESULT OF SELLERS CLEANING SYSTEMS CONSTANT PRODUCT IMPROVEMENT PROGRAM, PRODUCT CHANGES MAY OCCUR. AS SUCH, SELLERS CLEANING SYSTEMS RESERVES THE RIGHT TO CHANGE PRODUCT WITHOUT PRIOR WRITTEN NOTIFICATION

WWW.SELLERSCLEAN.COM

SHEET 3 OF 3

TITLE: JUMBO 6 BALL DRIVE

CAGE NO: 96046

DWG NO: CDJ6-500-BD-XX

REV: D

4

3

2

1

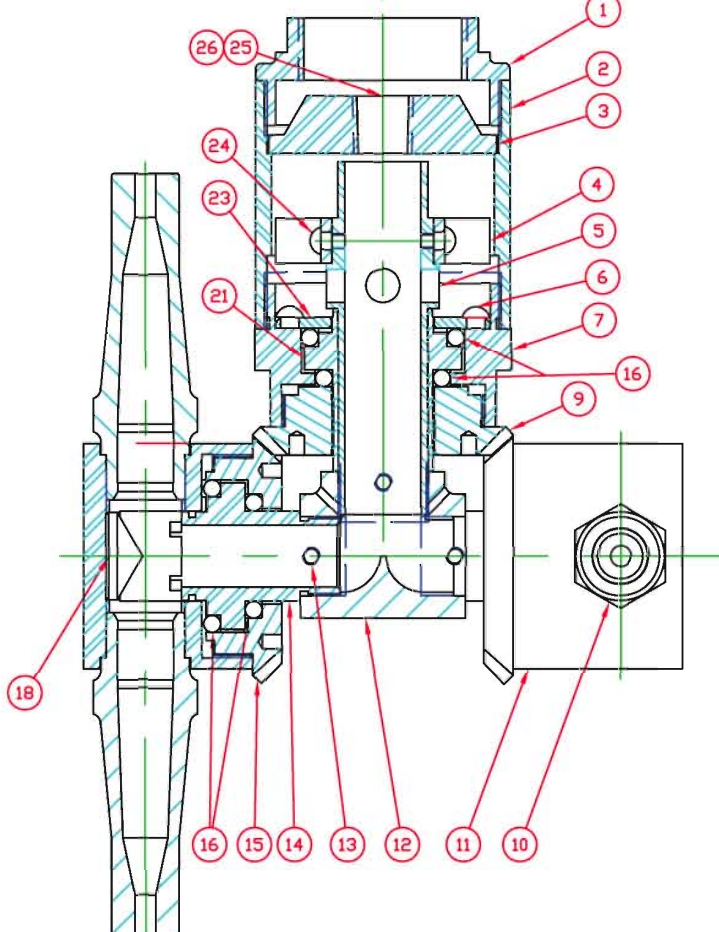
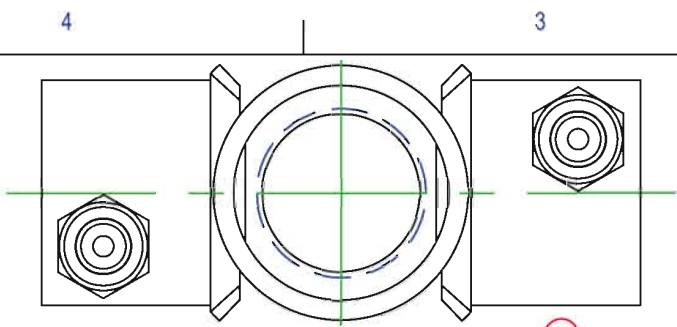

PART No.	ITEM #1	ITEM #3	ITEM #10
J6-500-HT-DA	75-1603	J6-101-P	J6-115-DA
J6-500-HT-FA	75-1603	J6-101-R	J6-115-FA
J6-500-HT-GA	75-1603	J6-101-S	J6-115-GA
J6-500-HT-DA-BSP	75-1603-BSP	J6-101-P	J6-115-DA
J6-500-HT-FA-BSP	75-1603-BSP	J6-101-R	J6-115-FA
J6-500-HT-GA-BSP	75-1603-BSP	J6-101-S	J6-115-GA

- NOTES:**
- ASSEMBLE UNIT WITH NOZZLES PERPENDICULAR TO EACH OTHER.
 - APPLY A SMALL AMOUNT OF NEVER SEIZE LUBRICANT (625-03561) TO ALL THREADS AT ASSEMBLY TO PREVENT GALLING.
 - WEIGHT PER UNIT = 12 LBS.
SHIPPING WEIGHT = 14 LBS.
 - USE THE FOLLOWING TORQUES FOR ASSEMBLY:
ITEMS #9 AND #15 TO 100 FT/LBS.
ITEM #13 TO 20 IN/LBS
ITEM #10 AND #1 TO 80 FT/LBS.
 - NOZZLE BODY INNER RACE HAS 18 BALL'S EACH.
NOZZLE BODY OUTER RACE HAS 24 BALL'S EACH.
 - VERTICLE SHAFT UPPER RACE HAS 25 BALL'S.
VERTICLE SHAFT LOWER RACE HAS 20 BALL'S.
 - SPARE PARTS KIT NUMBER J6-500-HT-SPK.
PARTS FOR THE KIT ARE IDENTIFIED WITH AN

ITEM NO.	QTY	RECD	PART OR IDENTIFYING NO.	NOMENCLATURE OR DESCRIPTION	MATERIAL/SPECIFICATION
26	1		75-1410	PLUG, SOCKET, 3/8" NPT	
25	1		J6-119-E	PLUG, SOCKET, 3/8" NPT	
24	2		2-61-1	SCREW, RH, #8-32 X 3/8"	18-8-SS
23	1		J6-106	PLATE, BEARING RETAINER	SS
21	1		J6-107	BUSHING, VERTICAL SHAFT BEARING	SS
18	2		J6-314-SSA	SPLITTER, FLOW (PRESS FIT INTO J6-313)	
	129		74-1172	BALL, STAINLESS, #187	SS
15	2		J6-309-EP	GEAR, 44 TEETH BEVEL	
	2		J6-112	SHAFT, NOZZLE HEAD	SS
13	3		74-324	SCREW, SH, #10-32 X 1/4"	
12	1		J6-110	TEE, VERTICAL & HORIZONTAL	316SS
11	2		J6-313	BODY, NOZZLE (2 NOZZLES)	SS
10	4		SEE CHART	NOZZLE	
9	1		J6-308-EP	GEAR, 45 TEETH BEVEL	
8	1		SEE BDM	WASHER, VERTICAL SHAFT BRG	
7	1		J6-305	CAP, LOWER, BODY	SS
6	3		2-60-1	SCREW, RH, #8-32 X 5/16	18-8-SS
5	1		J6-102	SHAFT, VERTICAL	SS
4	1		J6-104	ROTOR, 6-TOOTH	316SS
3	1		SEE CHART	MOTOR	316SS
2	1		75-1601	BODY, OUTER	SS
1	1		SEE CHART	CAP, INLET	SS

THIS PRINT IS AND CONTAINS PROPRIETARY INFORMATION OWNED EXCLUSIVELY BY SELLERS CLEANING SYSTEMS AND CLOUD TANK COMPANY. THIS RESTRICTION INCLUDES, BUT IS NOT LIMITED TO, THE CONDITION THAT THIS PRINT WILL ONLY BE USED AS A RECORD OR TO IDENTIFY OR INSPECT PARTS OR FOR OTHER INFORMATION PURPOSES, AND WILL NOT BE USED TO MANUFACTURE OR PROCURE THE MANUFACTURE OF THE PARTS SHOWN IN THIS PRINT BY ANY OTHER SOURCE THAN SELLERS CLEANING SYSTEMS AND CLOUD TANK COMPANY.

THIS DRAWING IS APPROVED FOR UNCONTROLLED DISTRIBUTION
 AS A RESULT OF SELLERS CLEANING SYSTEMS CONSTANT PRODUCT IMPROVEMENT PROGRAM, PRODUCT CHANGES MAY OCCUR. AS SUCH, SELLERS CLEANING SYSTEMS RESERVES THE RIGHT TO CHANGE PRODUCT WITHOUT PRIOR WRITTEN NOTIFICATION
 WWW.SELLERSCLEAN.COM SHEET 3 OF 3

TITLE: **JUMBO 6 HIGH TEMPERATURE** CAGE NO: 96046
 DWG NO: CDJ6-500-HT-XX REV: C